



Precision Plumbing Products
"Specify with Confidence - Install with Pride"

INSTALLATION PRO1-500 TRAP PRIMER VALVES

www.pppinc.net

- 1.) Flush line prior to installation.
- 2.) Use ribbon pipe seal tape - **ONLY**.
- 3.) Install valve plumb, observing the flow direction marked on the valve. **Do not over tighten.**
- 4.) The valve must be installed a minimum of 12" (305mm) above the finished floor.
- 5.) Do not install the valve where line pressures exceed 80 PSIG. at drinking fountains, or where hot/cold water lines are combined. This valve should never be installed on a hot water line.
- 6.) Effective operating range 20 to 80 PSIG (138 to 552 kpa).
- 7.) The valve must not be installed on a bypass.
- 8.) Failure to follow these instructions will make the product warranty null and void.

CAUTION

- A) Primer is factory pre-set, circumstances may dictate the need for further adjustment in the field.
 - A: To adjust: Using 3/16" hex key, turn adjusting screw clockwise until steady flow is produced.
 - B: Continue turning screw slowly clockwise until flow just stops.
- B) Cycle primer at least (5) times to ensure proper activity.
- C) The Trap Primer must be installed on a cold fresh water line of 1" dia. or less.
- D) Must be installed on the fixture supply line not to exceed 7 GPM.
- E) Do not install fixture on a combination hot/cold or a hot water fixture supply lines, at drinking fountains, or where water pressures exceed 80 PSIG.
- F) All floor drain supply lines must be clear to ensure proper discharge to trap. Failure to do so could result in water discharge through air gap port.

Precision Plumbing Products of Portland, Oregon (USA) warrants our manufactured products to be free from defects and workmanship under normal use and service. The sole and exclusive remedy for our manufactured products that do not conform to this limited and express warranty and our sole obligation under this limited and express warranty is to replace the defective part or product during the three year period after original installation. This warranty excludes any parts or products that are modified or improperly installed or installed where PH levels, chemical conditions or electrolysis prematurely degrade the product. We specifically disclaim any warranties or responsibility for defects due to quality, material, dimensional tolerances or quality control of any fitting or other third party supplied parts or components. **EXCLUSIONS OF ALL OTHER WARRANTIES INCLUDING IMPLIED WARRANTIES:** All other warranties, including the implied warranties of **MERCHANTABILITY** and fitness for a particular purpose, are **EXCLUDED** from this transaction and shall not apply to goods sold by us. The above warranties are in lieu of all other warranties and representations, express or implied, and all other obligations or liabilities on our part. We shall not be liable for consequential damages, loss of profit, interruption of business or any other special, incidental, or punitive damages suffered or sustained by Customer. Any part or products being returned under this warranty must have prior authorization by us. Any part or product received by us without a return of goods authorization will be returned to the shipper. All returned merchandise must be prepaid by shipper. Our personnel, including salespeople, as well as independent distributors and sales agents may have made oral statements about our products. Those statements are not warranties by us and should not be relied on by the buyer/customer/user. If you use this product you are agreeing to this warranty contract between us. This writing constitutes the final expression of the parties and is the complete and exclusive statement of that contract for warranties. Rev 05/09

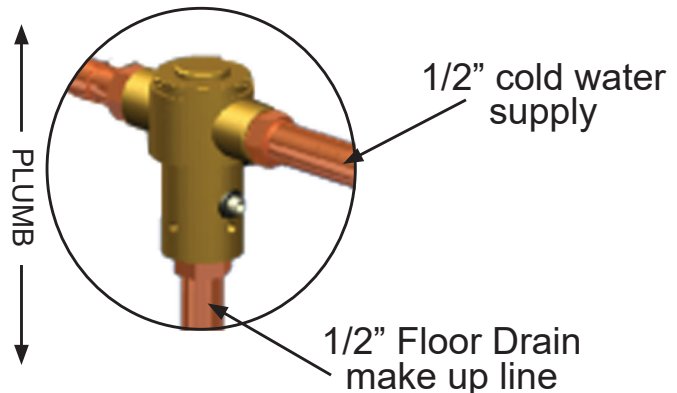

The Priming valve must have a min. elevation of 12" (305mm) above the finished floor.
Allow 1 foot of elevation for every 20 feet of distance run for floor drain make-up line.



JL Industries, Inc.

Precision Plumbing Products

Division of JL Industries, Inc.

802 SE 199th Ave
 Portland, Oregon 97233

T (503) 256-4010
 F (503) 253-8165

www.pppinc.net



MI-TPV-05 Rev 09/22